

1 and 1½ Hour Fire Rated MBMA Roof Systems

The Metal Building Manufacturers Association (MBMA) fire testing activities at Underwriters Laboratories, Inc. has resulted in U.L. listing in their Fire Resistance Directory three MBMA roof systems, U.L. Design No. P516 which utilizes a gypsum wallboard suspended ceiling and U.L. Designs No. P265 and P268 which use an acoustical tile lay-in suspended ceiling.

U.L. Design No. P516 provides not only a 1-hour fire resistance rating for the roof assembly but 1-hour protection for structural members located above the ceiling. U.L. Designs No. P265 and P268 utilize acoustical tile ceiling systems to provide a 1- and 1½ - hour roof/ceiling assembly fire resistance rating and also provides 1- and 1½ - hour protection to steel members above the ceiling. In addition, the acoustical tile ceilings may have light fixture penetrations and duct outlets in the ceiling if required.

An MBMA building with a fire rated roof assembly places the metal building in a totally new class of construction with the following advantages:

1. Allows the metal building to be used in areas previously restricted, such as gymnasiums, auditoriums, skating rinks, or high occupancy areas.
2. Places the metal building in Type IB or Type II Fire Resistive Type Construction in the three model building codes (BOCA,

ICBO, and SBCCI) if the one- and two-hour fire rated walls, columns, and floors are used in conjunction with the 1- or 1½ hour roof.

3. Changes the insurance rate from Construction Class 3 to Construction Class 5 reducing the rates by as much as 40 percent, as shown in MBMA Insurance Bulletin #5.

To take advantage of these fire rated roof systems, one should make a comparison of costs against a non-combustible metal building (standard metal building with no fire resistance ratings), or a sprinklered metal building, or against a Construction Class 4 where one-hour fire resistive walls are used with a non-fire rated, noncombustible roof. Rates must be developed to see if the return on the additional investment would be beneficial.

The most important avenue gained by having a 1- or 1½ - hour fire resistive roof assembly is to expand the market for metal buildings for those occupancies where codes* require Type IB or Type II construction. This also permits larger area metal buildings under the code for those occupancies requiring fire rated noncombustible construction.

The construction details for the U.L. listed MBMA roof assemblies are as follows:

*The building owner's design professional must determine and specify applicable load requirements.

Note: This bulletin was previously released as Insurance Bulletin #17

Design No. P516
Unrestrained Assembly Ratings - 1 Hr.
Unrestrained Beam Rating - 1 Hr.

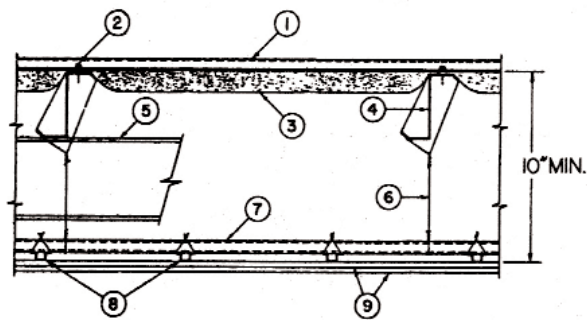

1. **Metal Roof Deck Panels*** - No. 26 MSG min. galvanized or painted steel. Panels continuous over two or more spans. End laps to occur over purlins with panels overlapped a min. of 4 in. A line of sealant or tape sealant may be used at panel side and end laps. See Roofing Materials and Systems Directory – Metal Roof Deck Panels (TJPV) category for names of manufacturers.
2. **Panel Fasteners** - As specified in the respective Classified Roof Deck Construction Number for the Metal Roof Deck Panel.
3. **Batts and Blankets*** - Any faced glass fiber batt material or mineral wool insulation bearing the UL Classification Marking. See Batts and Blankets* (BZJZ) Category in Fire Resistance Directory or Batts and Blankets* (BKNV) in Building Materials Directory for list of Classified Companies.
4. **Steel Roof Purlins** - C or Z-shaped, min. 8 in. deep, weighing min. 2.9 lb. per lineal ft. made from min. No. 16 MSG galvanized or painted steel. Spaced max. 60 in. O.C. Purlins may be stiffened at the supports if required per structural design.
5. **Beam** - Steel I beam sections designed as structural supports to the roof purlins. Min. weight of steel I beam is 2.9 lb. per lineal ft.

6. **Hanger Wire** - No. 12 SWG or heavier galvanized steel wire; twist-tied to steel roof purlins or joists. Hanger wire attachment spaced not over 60 in. O.C. along cold-rolled channel, and located at ends of the cold-rolled channels at walls. When alternate Steel Framing Members* (Item 8A or 8B) are used, hanger wires are spaced 48 in. O.C. (at every third main runner/cross tee intersection). Hanger wires also located adjacent to each main runner splice location.

7. **Cold-Rolled Channel** - Min. No. 16 MSG galvanized or painted steel channels, 1 ½ in. deep with 9/16 in. flanges.

8. **Furring Channel** - No. 25 MSG galvanized steel, 2 5/8 in. wide, 7/8 in. deep, spaced 24 in. O.C. perpendicular to cold-rolled channels: secured to each cold-rolled channel with double strand of No. 18 SWG galvanized steel wire. As an alternate to the furring channels, Steel Framing Members* (Item 8A or 8B) may be used.

8A. **Steel Framing Members** - (Not Shown) - As an alternate to Item 8. Main runners nom. 12 ft. long, spaced 48 in. O.C. cross tees, measuring 1 ½ in. across the flange and nom. 4 ft. long, installed perpendicular to main runners and spaced 16 in. O.C. Additional cross tees required 4 in. from and on each side of wallboard end joint.

8B. **Steel Framing Members** - (Not Shown) - As an alternate to Items 8 and 8A. Main runners nom. 12 ft. long, spaced 48 in. O.C. Cross channels, nom. 4 ft. long installed perpendicular to the main runners, spaced 16 in. O.C. Additional cross channels required 4 in. from and at each side of wallboard and joint.

USG Interiors, Inc. – Type RX main runner and cross channel.

Type DXLG cross tees.

Armstrong World Industries, Inc. -

Type DFR-8000

*Bearing UL Classification Marking

9. Wallboard Gypsum* - Any 5/8 in. thick gypsum wallboard bearing the UL Classification Marking as to Fire Resistance. Two layers of 5/8 in. thick by 48 in. wide sheets installed with long dimension perpendicular to the furring channels. Inner layer attached to furring channels using 1 1/4 in. long Type S bugle head steel screws spaced 8 in. O.C. along butted end joints and 12 in. O.C. in the field of the board. Butted end joints to occur midway between continuous furring channels and to be backed by joint backer channel which is centered on the end joints and extends 6 in. beyond both ends of the end joint. Butted end joints to be offset a min. of 24 in. in adjacent courses. Outer layer attached to the furring channels through inner layer using 1 7/8 in. long Type S bugle head steel screws spaced 8 in. O.C. at butted joints and 12 in. O.C. in the field. Butted end joints to be centered over continuous furring channels and be offset a min. of 12 in. from end joints of inner layer. Rows of screws on both sides of butted end joints of each layer shall be located 3/8 to 1/2 in. from end joints. Butted side joints of outer layer to be offset a min. of 18 in. from butted side joints of inner layer.

When Steel Framing Members* (Item 8A or 8B) are used, inner layer installed with long dimension perpendicular to cross tees with side joints centered along main runners and end joints centered along cross tees. Inner layer fastened to cross tees with 1 1/4 in. long Type S bugle head steel screws spaced 8 in. O.C. along butted end joints and 12 in. O.C. in the field of the board. End joints of adjacent wallboard sheets shall be staggered not less than 4 ft. O.C. Outer layer attached to the cross tees through inner layer using 1 7/8 in. long Type S bugle head steel screws spaced 8 in O.C. at butted end joints and 12 in. O.C. in the field. Butted end joints to be centered along cross tees and be offset a min. of 32 in. from end joints of inner layer. Rows of screws on

Butted side joints of outer layer to be offset a min. of 18 in. from butted side joints of inner layer.

See Wallboard Gypsum (CKNX) category for names of manufacturers.

*Bearing the UL Classification Marking

Design No. P265
Restrained Assembly Rating -
1 or 1½ Hr. See Item 3
Unrestrained Assembly Rating -
1 or 1½ Hr. See Item 3
Unrestrained Beam Rating - 1½ Hr.

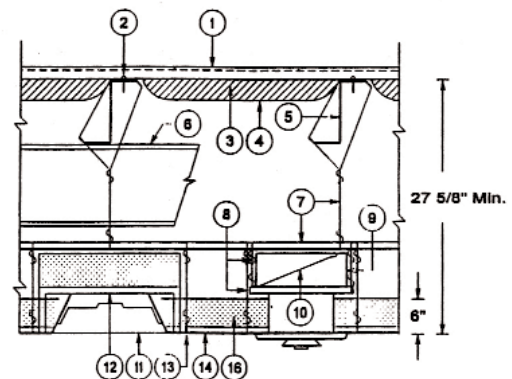

1. **Metal Roof Deck Panels*** - No. 26 MSG min. galvanized or painted steel. Panels continuous over two or more spans. End laps to occur over purlins with panels overlapped a min. of 4 in. A line of sealant or tape sealant may be used at panel side and end laps.

See Roofing Materials and Systems Directory – Metal Roof Deck Panels (TPJV) category for names of manufacturers.

2. **Panel Fasteners** - As specified in the respective Classified Roof Deck Construction Number for the Metal Roof Deck Panel.

*Bearing the UL Classification Marking

- 3. Batts and Blankets*** - For the 1 hr. ratings, faced compressible, min. 3 in., max. 4 in., thick glass fiber batt insulation, weighing between 0.6 and 0.7 pcf. Installed at the bottom side of the roof deck panels and supported by the steel mesh Item 4. For 1½ hr. Restrained and Unrestrained Assembly ratings, the thickness of the glass fiber batt insulation shall be 4 in. and the side edges of the batts must be overlapped a min. of 2 in. Any glass fiber batt material bearing the UL Classification Marking.

See Batts and Blankets* (BZJZ) Category in Fire Resistance Directory or Batts and Blankets* (BKNV) in Building Materials Directory for list of Classified Companies.

- 4. Steel Mesh** - Hexagonal shaped wire mesh, with 1 in. wide openings, made from No. 20 gauge galvanized steel wire. Draped over purlins under Insulation Item 3.
- 5. Steel Roof Purlins** - C- or Z-shaped, min. 8 in. deep, weighing min. 2.9 lb. per lineal ft., made from min. No. 16 MSG galvanized or painted steel. Spaced max. 60 in. O.C. purlins may be stiffened at the supports if required per structural design.
- 6. Beam** - Steel beam sections, min. 8 in. deep, designed as structural supports to the roof purlins. Min. weight of steel beam is 2.9 lb. per lineal ft.
- 7. Cold-Rolled Channels** - No. 16 MSG cold-rolled steel channels, 1½ in. deep min., with 9/16 in. flanges. Installed perpendicular to the purlins, spaced 24 in. O.C. and located as needed to support the ceiling. Cold-rolled channels supported by No. 12 SWG steel hanger wires, twist-tied to steel roof purlins. Hanger wire attachment to purlins not to exceed 60 in. O.C. along cold-rolled channel, and located at ends of cold-rolled channels at walls.

- 8. Hanger Wire** - No. 12 SWG galvanized steel wire, twist-tied to cold-rolled channels. Hanger wires shall be spaced 48 in. O.C. along main runners adjacent to intersections with cross tees, with additional wires located adjacent to main runner splices. One hanger wire is required at first hole of main runner web outside of the fixture grid module at each corner of light fixture, and at midspan of all 4 ft. cross tees.

- 9. Air Duct** - Min. 0.023 in. thick (No. 24 gauge) galvanized steel. Total area of duct openings per 100 sq. ft. of ceiling area not to exceed 576 sq. in. with area of individual duct openings not to exceed 576 sq. in. Max dimension of openings 30 in. Inside and outside faces of duct outlet throat protected with ⅝ in. thick ceramic fiber paper laminated to the metal. Duct supported by 1 in. deep, min. 0.053 in. thick (16 gauge) coldrolled steel channels spaced not over 48 in. O.C. suspended by No. 12 SWG galvanized steel wire.

- 10. Damper** - Min. 0.056 in. (16 gauge) galvanized steel, sized to overlap duct opening 2 in. min. Protected on both sides with 1/16 in. thick ceramic fiber paper laminated to the metal and held open with a Fusible Link (Bearing the UL Listing Mark). In lieu of the damper described above, Duct Outlet Protection System A, as described in the General Information Section may be used with steel ducts.

- 11. Fixtures, Recessed Light** (Bearing the UL Listing Mark) - Fluorescent lamp type, steel housing, nominal 2 by 4 ft. size. Fixtures spaced so their area does not exceed 24 sq. ft. per 100 sq. ft. of ceiling area. Wired in conformance with the National Electric Code.

*Bearing the UL Classification Marking

- 12. Fixture Protection – Acoustical Material*** - Cut to form a five-sided enclosure, trapezoidal in cross-section. The fixture protection consists of 23 ¾ by 47 ¾ in. by 5/8 or ¾ in. thick top piece; two 8 7/8 by 47 ¾ in. by 5/8 or ¾ in. thick side pieces, and two 5 7/8 by 23 ¾ in. by 5/8 or ¾ in. thick end pieces. The side pieces and top pieces are laid in place and each end piece attached to the top piece with three 8d nails spaced 8 in. O.C.

**Armstrong World Industries, Inc. –
5/8 in. Type PC: 5/8 or ¾ in. Type P**

- 13. Steel Framing Members*** - Main runners, nom. 12 ft. long, spaced 4 ft. O.C. Cross tees, nom. 4 ft. long, installed perpendicular to main runners and spaced 2 ft. O.C. For nom. 24 by 24 in. panels, cross tees nom. 2 ft. long installed perpendicular to 4 ft. cross tees and spaced 4 ft. O.C.

**Armstrong World Industries, Inc. -
Types AFG, FST-6000, -8000**

- 13A. Steel Framing Members*** - For use with nom. 600 by 600 or 1200 mm. metric size panels described under Item 14. Main runners nom. 3600 mm. long spaced 1200 mm. O.C. Cross tees nom. 1200 mm. long installed perpendicular to main runners and spaced 600 mm. O.C. For nom. 600 by 600 mm. panels, cross tees nom. 600 mm. long installed perpendicular to 1200 mm. cross tees and spaced 1200 mm. O.C.

**Armstrong World Industries, Inc. -
Types AFG, FST-6000, -8000**

- 14. Acoustical Material*** - Nom. 24 by 24 or 48 in. by 5/8 or ¾ in. thick lay-in panels. Border panels supported at walls by min. 0.016 in. thick (26 gauge) painted steel angles with 7/8 in. legs. (S) = Surface perforations.

**Armstrong World Industries, Inc. –
¾ in. Type P(S) or 5/8 in. Type PC(S)**

- 15. Hold Down Clips (Not Shown)** - No. 24 MSG spring steel, placed over cross tees 2 ft. O.C.

- 16. Batts and Blankets*** - Nom. 24 in. wide by 6 in. thick batts or rolls of glass fiber insulation placed directly on the back of ceiling panels and steel framing members (grid system) so as to cover both the ceiling panels and the grid with end joints staggered with respect to the grid, where possible. Nom. 24 in. wide by 48 in. long by 6 in. thick piece placed over top piece of light fixture protection. Density of glass fiber insulation to be between 0.58 and 0.78 pcf. Batts and Blankets to be Classified with respect to Surface Burning Characteristics, with Flame Spread value of 25 or less.

See Batts and Blankets* (BZJZ) Category in Fire Resistance Directory or Batts and Blankets* (BKNV) Category in Building Materials Directory for list of Classified Companies.

*Bearing the UL Classification Marking

Continued on next page

Design No. P268
Restrained Assembly Rating -
1 or 1½ Hr. See Item 3
Unrestrained Assembly Rating -
1 or 1½ Hr. See Item 3
Unrestrained Beam Rating - 1 ½ Hr.

As Classified in Underwriters Laboratories, Inc.
 Fire Resistance Directory, dated 1996,
 and any subsequent issues.
 Documented by File R4651, Project 94NK2226.

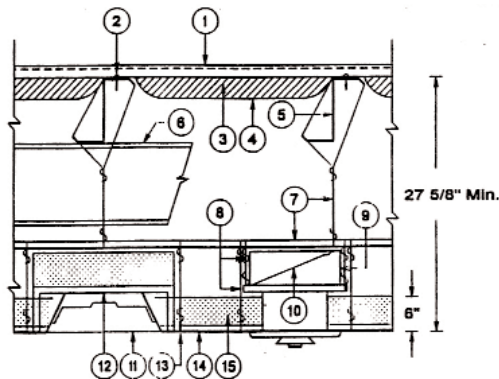

1. **Metal Roof Deck Panels*** - No. 26 MSG min. galvanized or painted steel. Panels continuous over two or more spans. End laps to occur over purlins with panels overlapped a min. of 4 in. A line of sealant or tape sealant may be used at panel side and end laps.

See Roofing Materials and Systems Directory – Metal Roof Deck Panels (TPJV) category for names of manufacturers.
2. **Panel Fasteners** - As specified in the respective Classified Roof Deck Construction Number for the Metal Roof Deck Panel.
3. **Batts and Blankets*** - For the 1 hr. ratings, faced compressible, min. 3 in., max. 4 in., thick glass fiber batt insulation, weighing between 0.6 and 0.7 pcf. Installed at the bottom side of the roof deck panels and supported by the steel mesh Item 4. For 1 ½ hr. Restrained and Unrestrained Assembly ratings, the thickness of the glass fiber batt insulation shall be 4 in.

and the side edges of the batts must be overlapped a min. of 2 in. Any glass fiber batt material bearing the UL Classification Marking.

See Batts and Blankets* (BZJZ) Category in Fire Resistance Directory or Batts and Blankets* (BKNV) in Building Materials Directory for list of Classified Companies.

4. **Steel Mesh** - Hexagonal shaped wire mesh, with 1 in. wide openings, made from No. 20 gauge galvanized steel wire. Draped over purlins under Insulation Item 3.
5. **Steel Roof Purlins** - C- or Z- shaped, min. 8 in. deep, weighing min. 2.9 lb per lineal ft., made from min. No. 16 MSG galvanized or painted steel. Spaced max. 60 in. O.C. Purlins may be stiffened at the supports if required per structural design.
6. **Beam** - Steel beam sections, min. 8 in. deep, designed as structural supports to the roof purlins. Min. weight of steel beam is 2.9 lb per lineal ft.
7. **Cold-Rolled Channels** - No. 16 MSG cold-rolled steel channels, 1 ½ in. deep min., with 9/16 in. flanges. Installed perpendicular to the purlins, spaced 24 in. O.C. and located as needed to support the ceiling. Cold-rolled channels supported by No. 12 SWG steel hanger wires, twist-tied to steel roof purlins. Hanger wire attachment to purlins not to exceed 60 in. O.C. along cold-rolled channel, and located at ends of cold-rolled channels at walls.
8. **Hanger Wire** - No. 12 SWG galvanized steel wire, twist-tied to cold-rolled channels. Hanger wires shall be spaced 48 in. O.C. along main runners adjacent to intersections with cross tees, with additional wires located adjacent to main runner splices. One hanger wire is required at first hole of main runner web outside of the fixture grid module at each corner of light fixture, and at midspan of all 4 ft. cross tees.

*Bearing the UL Classification Marking

- 9. Air Duct** - Min. 0.023 in. thick (No. 24 gauge) galvanized steel. Total area of duct openings per 100 sq. ft. of ceiling area not to exceed 576 sq. in. with area of individual duct openings not to exceed 576 sq. in. Max. dimension of openings 30 in. Inside and outside faces of duct outlet throat protected with 1/16 in. thick ceramic fiber paper laminated to the metal. Duct supported by 1 ½ in. deep, min. 0.053 thick (16 gauge) cold-rolled steel channels spaced not over 48 in. O.C. suspended by No. 12 SWG galvanized steel wire.
- 10. Damper** - Min. 0.056 in. (16 gauge) galvanized steel, sized to overlap duct opening 2 in. min. Protected on both sides with 1/16 in. thick ceramic fiber paper laminated to the metal and held open with a Fusible Link (Bearing the UL Listing Mark). In lieu of the damper described above, Duct Outlet Protection System A, as described in the General Information Section may be used with steel ducts.
- 11. Fixtures, Recessed Light** (Bearing the UL Listing Mark) - Fluorescent lamp type, steel housing, nominal 2 by 4 ft. size. Fixtures spaced so their area does not exceed 24 sq. ft. per 100 sq. ft. of ceiling area. Wired in conformance with the National Electric Code.
- 12. Fixture Protection – Acoustical Material*** - Cut to form a five-sided enclosure, trapezoidal in cross-section. The fixture protection consists of 23 ¾ by 47 ¾ in. by 5/8 or ¾ in. thick top piece; two 8 7/8 by 47 ¾ in. by 5/8 or ¾ in. thick side pieces, and two 5 7/8 by 23 ¾ in. by 5/8 or ¾ in. thick end pieces. The side pieces and top pieces are laid in place and each end piece attached to the top piece with three 8d nails spaced 8 in. O.C.

USG Interiors Inc. - 5/8 in. Type FR-4;
or ¾ in. Types FR-83, GR-1 or FR-81

- 13. Steel Framing Members*** - Main runners, nom. 12 ft. long, spaced 4 ft. O.C. Cross tees, nom. 4 ft. long, installed perpendicular to main runners and spaced 2 ft. O.C. Cross tees nom. 2 ft. long installed perpendicular to 4 ft. cross tees and spaced 4 ft. O.C.

U.S.G. Interiors, Inc. -
Types DXL, DXLA, or ZXLA

- 14. Acoustical Material*** - Nom. 24 by 24 or 48 in. by 5/8 or ¾ in. thick lay-in panels. Border panels supported at walls by min. 0.016 in. thick (26 gauge) painted steel angles with 1 in. legs. See Acoustical Materials (BYIT), USG Interiors, Inc., for specific tile details.

USG Interiors, Inc. – 5/8 in. Type FR-4
or ¾ in. Types FR-83, GR-1, or FR-81

- 15. Batts and Blankets*** - Nom. 24 in. wide by 6 in. thick batts or rolls of glass fiber insulation placed directly on the back of ceiling panels and steel framing members (grid system) so as to cover both the ceiling panels and the grid with end joints staggered with respect to the grid, where possible. Nom. 24 in. wide by 48 in. long by 6 in. thick piece placed over top piece of light fixture protection. Density of glass fiber insulation to be between 0.58 and 0.78 pcf. Batts and Blankets to be Classified with respect to Surface Burning Characteristics, with Flame Spread value of 25 or less. See Batts and Blankets* (BZJZ) Category in Fire Resistance Directory or Batts and Blankets* (BKNV) Category in Building Materials Directory for list of Classified Companies.

*Bearing the UL Classification Marking

Additional Information:
Metal Building Manufacturers Association, Inc.
1300 Sumner Avenue • Cleveland, Ohio 44115-2851
216-241-7333 • 216-241-0105 (fax)
Email: mbma@mbma.com
Website: www.mbma.com